



**ebmpapst**

# Mitigating Harmonics in Custom Air Handlers with EC Fans

White Paper



Harmonic distortion in the data center has become an important topic in the engineering design world. To understand why, it is necessary to review some history and understand how data center cooling equipment and design philosophy has evolved over time.

Harmonic distortion in the data center electrical distribution system leads to energy inefficiency and can lead to damage of motors and other electrical components. This distortion is generated by the variable speed devices that have become ubiquitous to the data center cooling infrastructure. One of the most numerous variable speed applications found in the white space are the fans used to distribute cooling air to the server racks.

A decade and a half ago data centers were typically designed with constant flow rate fans. This made sense at the time because the heat loads were fairly constant and concern over data center energy efficiency was a secondary concern. Prior to 2010 there were no computer room energy efficiency metrics that computer room air conditioners needed to meet, nor was there an energy efficiency standard that applied to data centers. That all changed with the publication of ASHRAE 90.1-2010.

As the demand for data computation and storage has increased the energy efficiency of the cooling systems within the data center has become much more critical for both economical and environmental concerns.

At the turn of this century the average computer room air handler was designed around forward curved, dual inlet, centrifugal fans driven by an AC induction motor through a belt drive system. The drive system, and therefore air flow rate, was typically adjustable through the belt and sheave system. The fan speed was set during commissioning and remained constant during day-to-day operation. As time passed and the highly virtualized data center experienced varying heat loads, data center designers and end users looked for ways to save energy by varying the volumetric air flow rates to match the actual cooling load. An early design approach to varying the air flow rate was to introduce a variable frequency drive to the existing units to ramp the flow rate up and down as the cooling load dictated. Though this was a vast improvement over the fixed speed approach there were still issues of inefficiencies due to belt and VFD losses as well as the continuing problem of belt dust contamination of the servers. In 2005 STULZ USA began the switch to electronically commutated (EC) backward inclined plenum style fans built by ebm-papst. This single assembly replaced the forward curved centrifugal fan, sheaves, belts, VFD, and AC induction motor. The EC fan provided higher mechanical and electrical efficiencies, produced lower noise levels and eliminated the belt dust problem.

Initially, little attention was paid to mitigating harmonic distortion. This changed as data centers got larger, and the cooling systems have grown in size, as have the individual computer room air handlers. Computer room air handlers may now have in excess of 12 EC fans moving as much as a hundred thousand cubic feet per minute of cooling air. As the number and power of these variable speed devices increased so did the negative effects of harmonic distortion.

Due to the variable nature of EC fan operation (or VFD operation), harmonic distortion can be introduced into the electrical distribution system. This white paper will show how we control and limit the distortion and its associated negative effects.

### **EC Fans vs AC Motors with VFDs**

To improve energy efficiencies in today's modern custom air handlers, highly efficient electronically commutated (EC) fans are often incorporated for air movement. This is because these fan systems can improve efficiencies over conventional AC motors equipped with variable frequency drives (VFDs) by 30% or more. An EC fan incorporates a brushless DC permanent magnet motor (BLDC) controlled by an integrated rectifier, inverter and smart electronics. BLDC motors, with efficiencies greater than 90%, provide a more effective ventilation system so that 'free cooling' becomes more easily achievable which contributes to the energy savings potential. Also, air distribution can be improved with multiple fan arrays allowing upstream or downstream components, such as filters or heat exchangers, to receive a more even air flow thereby improving air filtering and heat transfer efficiency.

In striving towards reliable and efficient systems, one significant factor sometimes overlooked is electrical harmonic distortion. One of the few things common with AC/VFD and EC fan systems is that they are both harmonic generating, non-linear loads. Without proper harmonic mitigation, non-linear loads can distort the AC power distribution and possibly expose a mission critical facility to electrical issues, such as overheating distribution equipment and failure of sensitive equipment connected to the same electrical bus. If harmonics are not effectively mitigated, larger UPS systems and larger power generators may also be required. So investing in proper harmonic solutions compliments the energy savings efforts.

Although both AC and EC systems require harmonic mitigation at times, their solutions can be different. Fortunately, with recent developments in this field, a relatively easy to apply harmonic mitigation solution is available which can ensure that the energy savings of EC fans can be realized without the negative effect of poor power quality.

## Power and Energy Savings - EC vs Conventional AC

EC fans designed for operation on a 3-phase AC supply, include an integrated circuit board with built-in rectifier, EMC protection, DC link capacitor(s), and an inverter module with IGBTs to control the commutation to a brushless DC (BLDC) motor. The BLDC motor includes permanent magnets on its rotor. Permanent magnets have allowed manufacturers to design EC fans with a smaller footprint than fans utilizing traditional AC induction squirrel cage motor construction. The permanent magnet motors induce the required rotor flux without requiring current to be induced in separate rotor windings. This eliminates  $I^2R$  losses in the rotor, which is a major reason for the improved efficiency over conventional VFD controlled AC induction motors.

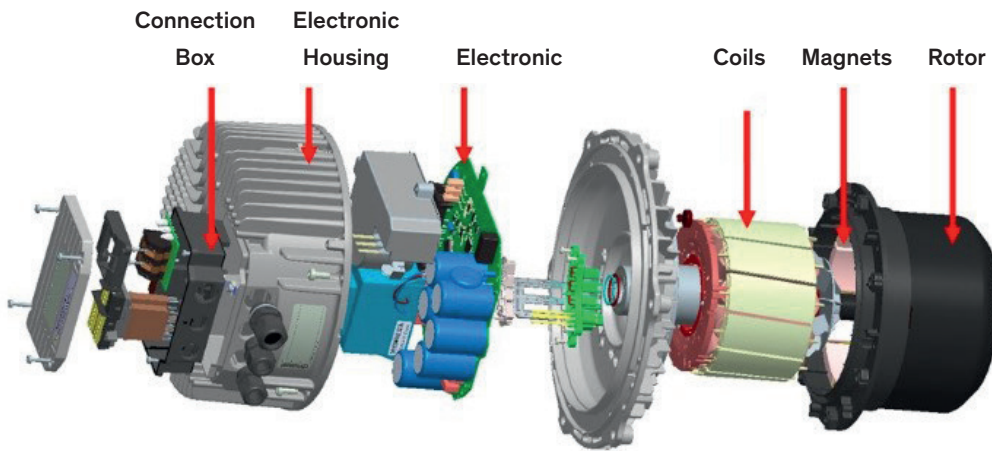

**FIG 1:** Typical EC Motor

The best EC solutions, such as those provided by ebm-papst, are designed by one manufacturer. ebm-papst designs and builds the entire system; motor, electronics, and air mover. This provides the utmost in product reliability and proven product performance. A complete fan system can be perfectly tailored to all operating conditions providing additional energy savings potential.

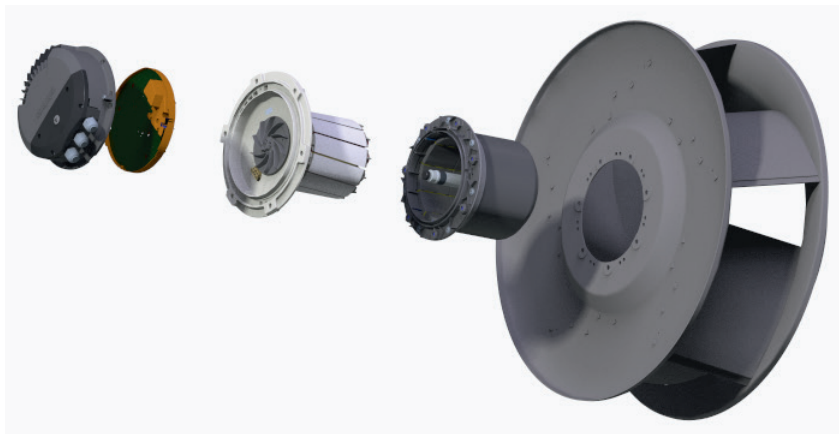

**FIG 2:** Components of a Complete EC Fan System

The energy savings benefits of EC fans are beyond the overall system efficiency at full speed. In modern systems, modulation of fan speed is increasingly used alongside variable speed compressors and this is where EC technology performs best. EC motors offer speed ranges unparalleled by other technology. AC with VFD solutions typically can only go as low as 45 - 50% of nominal motor speed for reliable starts under all conditions and do this with less improvements in efficiency at 50% speed. Since most motors are not made for a specific application, air handling unit manufacturers typically design headroom to ensure they hit their claimed air flow ratings, so it is common to see motors oversized by 10 or 20%. This is especially true for custom AHU's where the project would be built only once and years of R&D are not invested. Therefore, in such situations, the AC/VFD may only be able to control at 60% speeds or higher. EC fans can reliably and efficiently operate as low as 10% or less than nominal.

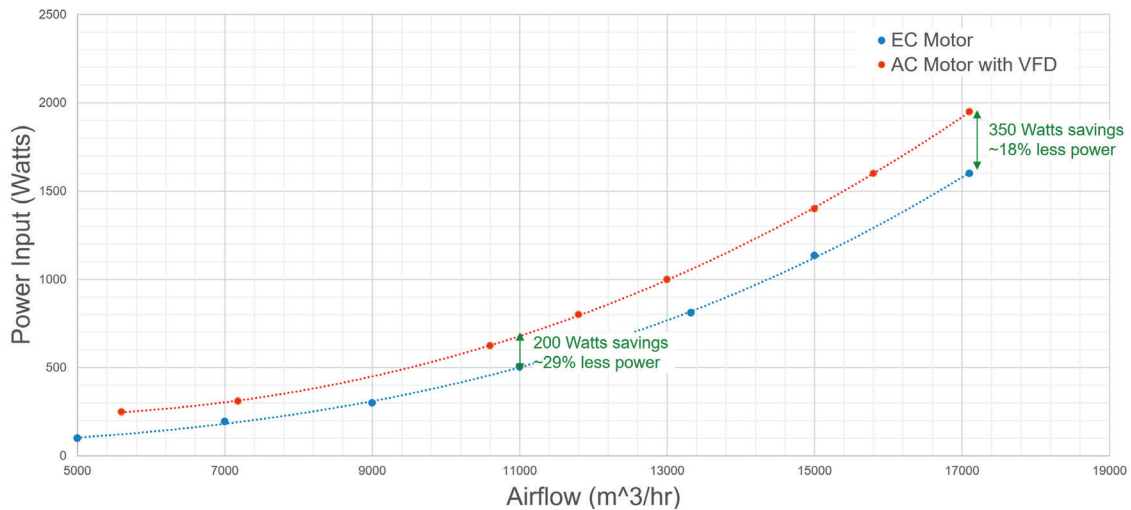

**Fig. 3: Comparison of Energy Consumption of EC Motor vs AC Motor with VFD**

## Power Quality Analysis

The rectifier/inverter configurations of both the AC VFD and the EC fan operate in very similar manners (Fig. 4). The 3-phase rectifier, often referred to as 6-Pulse, converts incoming AC voltage to DC. In the VFD case, the inverter then creates a simulated AC variable voltage and frequency by systematically switching the DC voltage to the output phases through six IGBT power switches. The rectifier draws current in pulses as shown in Fig. 5 which contain harmonic frequencies (Fig. 6). In the EC fan case, the inverter controls the DC voltage supplied to the BLDC motor through switching of the IGBTs.

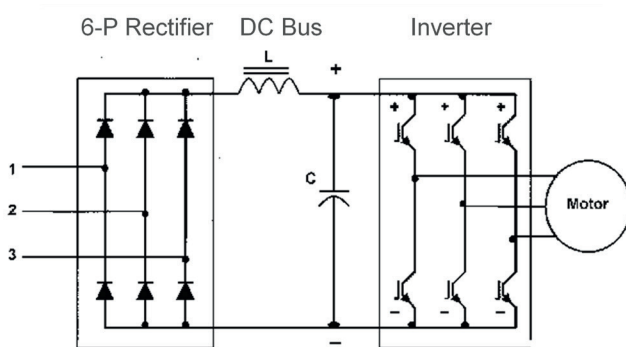

**FIG 4:** Schematic Diagram for both AC VFD and EC Fan

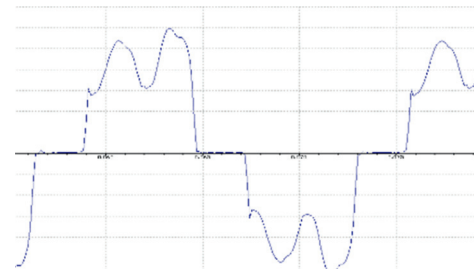

**FIG 5:** Typical 6-Pulse rectifier input current waveform - VFD with DC reactor or EC Fan

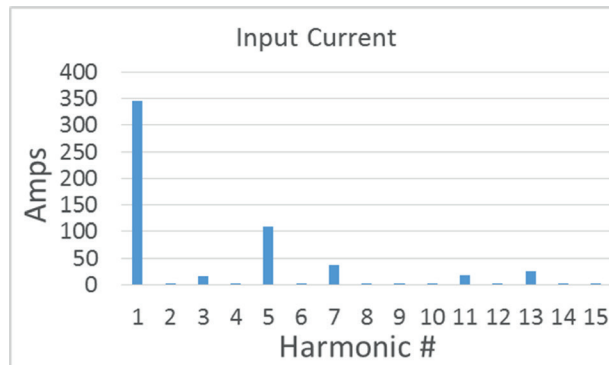

**FIG 6:** Typical 6-Pulse rectifier input current spectrum - VFD with DC reactor or EC Fan (THDi - 35%)

The negative effects of harmonics include:

1. Reduction in True Power Factor due to the harmonic reactive power
2. Higher capital costs of onsite power generation and UPS systems
3. Potential for overheating of electrical distribution equipment, due to harmonic losses
4. An increase in voltage distortion which can contribute to equipment malfunction and premature failure, especially when operating on back-up generators

To address these concerns, many engineers are applying the harmonic limits of IEEE Std 519. When this is done, some form of harmonic mitigation must be employed. For AC VFDs there are several options for harmonic mitigation including a passive wide spectrum harmonic filter that can reduce THDi levels to < 5% at full load.

While some of these filters are compatible with older EC fans, they are not always compatible with the latest topologies. A lower DC bus capacitance has been incorporated in order to increase power density by reducing electronics. This results in some reduction in current harmonic distortion without the need for an AC or DC reactor because the pulsed currents are broadened making the waveshape slightly more sinusoidal. Relatively high levels of current harmonics remain however and reducing them through some form of harmonic mitigation is still often necessary, as it is with AC VFDs. This is especially true when the requirement is 5% THDi.

The challenge is that conventional forms of harmonic mitigation are not effective because simply adding inductance, such as a line reactor or conventional passive harmonic filter, can cause the EC fan to become unstable. In fact, any high impedance source, including synchronous generators, can cause instability if the impedance is too high to provide the required peak currents for this non-linear load. This must be taken into consideration when applying harmonic mitigation on EC fans or other non-linear loads and when using these fans in environments with emergency backup generators, such as data centers or healthcare facilities, with or without harmonic mitigation.

## Harmonic Mitigation for EC Fan Applications

### Wide Spectrum Harmonic Filter

As mentioned earlier, one of the more effective forms of passive harmonic mitigation for 3-phase rectifiers is the wide spectrum harmonic filter (WSHF). This approach is series connected and incorporates a combination of a blocking element and a tuned filtering element as shown in Fig. 7.

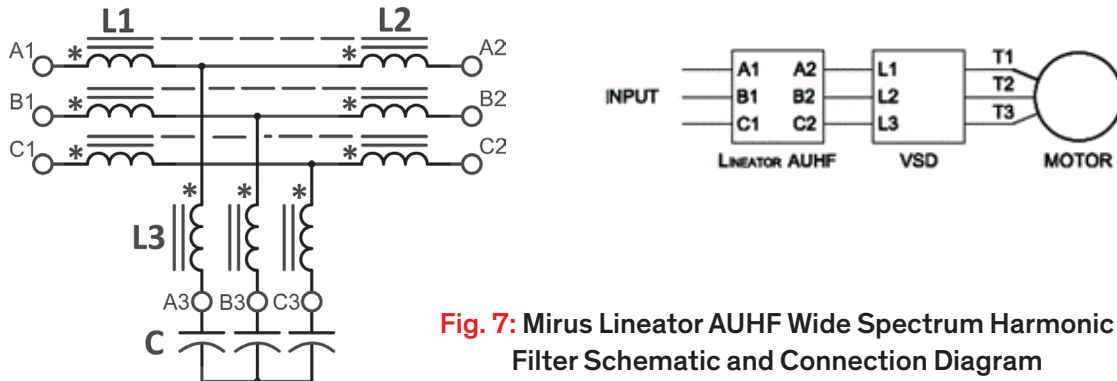

**Fig. 7: Mirus Lineator AUHF Wide Spectrum Harmonic Filter Schematic and Connection Diagram**

Important in the design of an effective filter is the prevention of harmonic importation from the line side of the filter. Without this ability, a filter could easily be overloaded when installed on a power system where other harmonic generating, non-linear loads exist on the same bus. This can be achieved by tuning the filter, as seen from the input terminals, to near the 4th harmonic, comfortably below the predominant harmonics of 3-phase rectifiers. When applied to a conventional VFD, the VFD's relatively high level of DC bus capacitance allows for stable operation and very effective harmonic mitigation.

But when applying these filters to inverters with low DC bus capacitance, as is found in some of the newest EC fan designs, unstable operation can occur due to resonance between the inverter's capacitance and the filter or power system's inductance.

### Resonant Circuits between Power System, Harmonic Filter and EC Fan

Power systems and the loads they supply can have issues with resonance when harmonic distortion is high. Resonance occurs at a certain frequency,  $f_0$ , when the capacitive reactance and inductive reactance at that frequency are essentially equal (Fig. 8). If this occurs at a harmonic frequency that is prevalent in the power system, the harmonic can be amplified resulting in high levels of both current and voltage distortion. When the resonance is between the power system and a load, such as an EC fan, this can lead to instability, overheating, high DC bus voltage and even component failure.



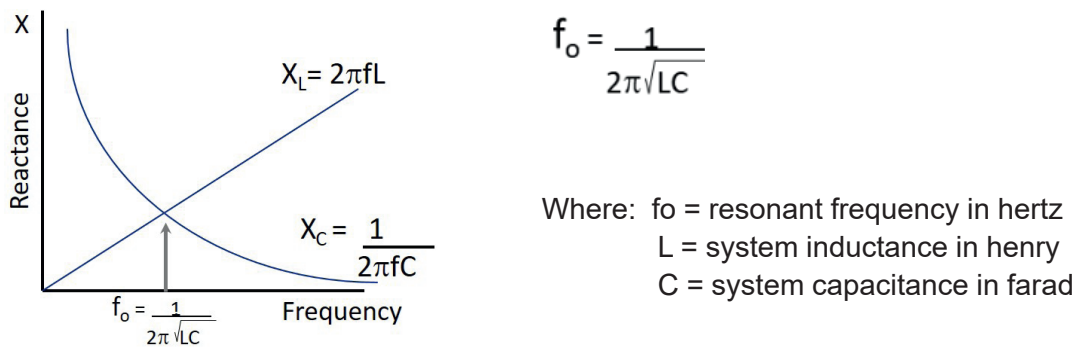
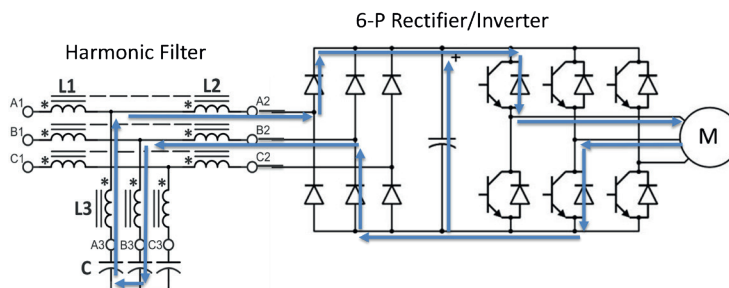

**Fig. 8: Reactance curves and resonant frequency,  $f_o$**

Fig. 9 shows a resonant circuit that exists between the harmonic filter and the rectifier/inverter. The resonant frequency is determined by the total capacitance of the inverter DC bus capacitors,  $C_{dc}$ , in series with two phases of the filter’s capacitance,  $C$ , and the filter inductances of  $L2$  and  $L3$ .

In a typical VFD circuit, the DC bus capacitance used will be in the mF range while the harmonic filter capacitance will be in the  $\mu F$  range. This means that the DC bus capacitance has significantly more influence on the resonant circuit than the filter capacitance. The DC bus capacitance is usually high enough to result in a resonant frequency substantially below the 5th harmonic and therefore, there will not be any amplification of the characteristic harmonics generated by the 6-Pulse rectifier. The result is a stable operation with the filter installed.

However, in most EC fan designs, DC bus capacitance is in the  $\mu F$  range, so the filter capacitors have an influence on the resonant circuit. The combined capacitance often increases the resonant frequency above the 5th harmonic and into the range where 6-Pulse rectifier harmonics are present. This then results in amplified harmonics leading to unstable operation, high DC bus voltages, poor harmonic mitigation and even component failures.



**Fig. 9: Parallel resonant circuit between filter and rectifier/inverter**

Fig. 10 shows a second resonant circuit that exists between the power system and the rectifier/inverter. Again, the DC bus capacitance has a major influence on this series resonant circuit. As with the parallel resonant circuit, when DC bus capacitance is high, it usually results in a resonant circuit with the power system that is below the 5th harmonic. Power system inductance will simply move this resonant point further down and away from prevalent harmonics.

However, with low DC bus capacitance, the resonant point can be above the 5th where the power system inductance will have influence. As a result, many EC fan applications will have instability issues when connected to 'weak' power sources, such as an AC reactor, relatively small transformer or high impedance synchronous generator. For application on EC fans, the harmonic filter must be designed to move the resonant point back below the 5th harmonic to eliminate instability.

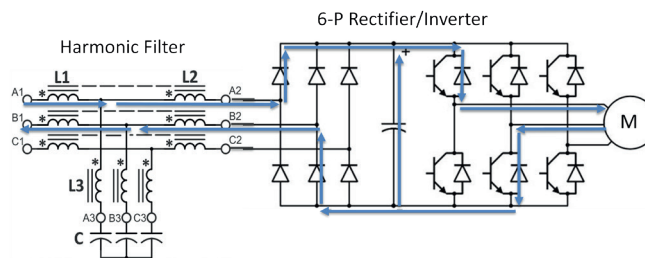

**Fig. 10: Series resonant circuit between power system, filter and rectifier/inverter**

## Factory Test Results for Data Center Custom Air Handler Applications

A 15 HP, 480 V, 60 Hz Lineator AUHF-HP2 harmonic filter was tested on an array of 4 x 3.75 HP EC fans at Mirus' factory near Toronto Canada (Fig. 11). The fans were run through their full operating range and measurements taken at 100 rpm speed intervals (Table 1). Current harmonic distortion at full load was well below the targeted level of 5% and the critical DC-Link voltage level of the fans remained well within acceptable operating levels. As a matter of working principle, a passive filter generates a voltage rise. It is important that the filter design minimizes this voltage rise and to check compliance with the allowed maximum voltage at fan input in standby operation and all load conditions. Excessive voltage rise could lead to a reduction of the nominal voltage range or the voltage tolerance range. No signs of high DC voltage or instability appeared at any speed point.

Fig. 12 plots the harmonic distortion levels over the full operating range. Total Current Harmonic Distortion (THDi) was below 4% at full load and only slightly exceeded 8% at any load level. When plotted as Current Total Demand Distortion (TDDi), the value remained well under 5% over the full operating range. TDDi is defined in IEEE Std 519 and calculated to be  $THDi \times \text{Measured Current} / \text{Maximum Current}$ .



**Fig. 11: Array of 4 × 3.75 HP EC Fans during Factory Testing**

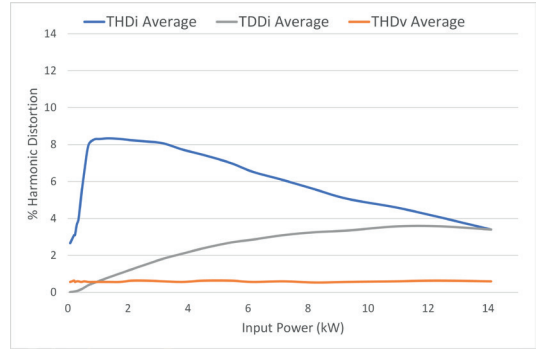

**Fig. 12 Harmonic Distortion Levels of Current and Voltage on 4 × 3.75 HP EC Fans with WSHF**

Speed (RPM)	Vrms at Filter Input (V)			Irms at Filter Input (V)			THDv at Filter Input (%)				THDi at Filter Input (%)				TDDi	P at Filter Input (kW)	Vrms at Filter Output (V)				DC-Link Voltage of Fan
	A	B	C	A	B	C	A	B	C	Avg	A	B	C	Avg			A	B	C	Avg	
0	480	479	483	4.7	4.7	4.7	0.6	0.6	0.5	0.6	2.5	3.6	1.9	2.7	0.0	0.08	513	514	516	514	730
100	480	480	482	4.7	4.7	4.7	0.7	0.7	0.5	0.6	2.6	3.8	2.9	3.1	0.0	0.21	512	515	517	515	723
200	480	480	482	4.7	4.7	4.7	0.6	0.6	0.5	0.6	2.6	3.8	2.9	3.1	0.1	0.24	515	516	518	516	723
300	480	481	483	4.7	4.7	4.7	0.6	0.6	0.6	0.6	3.1	4.1	3.8	3.7	0.1	0.3	515	516	518	516	720
400	481	481	483	4.7	4.7	4.7	0.6	0.6	0.6	0.6	3.6	4.4	3.9	4.0	0.1	0.36	515	516	518	516	720
500	481	481	484	4.7	4.7	4.7	0.6	0.6	0.5	0.6	4.4	5.9	5.5	5.3	0.2	0.45	515	516	518	516	720
600	481	481	483	4.7	4.7	4.7	0.7	0.6	0.5	0.6	5.5	7.8	6.3	6.5	0.3	0.55	515	516	517	516	716
700	481	481	484	4.7	4.7	4.7	0.6	0.6	0.5	0.6	7.1	9.2	7.6	8.0	0.4	0.69	515	516	517	516	709
800	482	482	484	4.7	4.7	4.7	0.6	0.6	0.5	0.6	7.8	9.1	7.9	8.3	0.5	0.87	515	516	517	516	702
900	482	481	484	4.7	4.8	4.8	0.5	0.6	0.6	0.6	8.9	8	8	8.3	0.6	1.08	515	515	517	516	698
1000	481	481	484	4.8	4.9	4.9	0.6	0.6	0.5	0.6	8.9	8.2	7.9	8.3	0.8	1.35	515	516	517	516	695
1100	481	481	483	4.9	5	5	0.6	0.6	0.5	0.6	8.9	8.2	7.8	8.3	1.0	1.74	515	516	517	516	695
1200	482	481	483	5.1	5.2	5.2	0.6	0.7	0.6	0.6	8.7	8.2	7.8	8.2	1.2	2.13	515	516	517	516	695
1300	482	481	483	5.4	5.5	5.5	0.7	0.6	0.6	0.6	8.7	8	7.8	8.2	1.5	2.61	515	515	516	515	695
1400	482	481	484	5.8	5.9	6.95	0.7	0.6	0.5	0.6	8.5	8	7.7	8.1	1.8	3.18	515	515	516	515	695
1500	481	482	484	6.3	6.3	6.3	0.6	0.6	0.5	0.6	8.1	7.7	7.4	7.7	2.1	3.81	516	516	517	516	691
1600	481	481	483	6.8	6.9	6.9	0.7	0.6	0.6	0.6	7.7	7.5	7.1	7.4	2.4	4.53	516	516	517	516	691
1700	482	481	484	7.5	7.5	7.5	0.7	0.6	0.6	0.6	7.4	7	6.6	7.0	2.7	5.43	516	516	516	516	691
1800	482	481	484	8.2	8.3	8.2	0.6	0.6	0.5	0.6	6.9	6.5	6.2	6.5	2.8	6.15	515	515	515	515	688
1900	482	484	484	9.3	9.3	9.2	0.6	0.6	0.6	0.6	6.4	6.1	5.7	6.1	3.1	7.2	514	512	513	513	685
2000	482	481	484	10.2	10.2	10.1	0.6	0.5	0.5	0.5	5.8	5.5	5.4	5.6	3.3	8.25	510	508	509	509	678
2100	482	481	484	11.7	11.6	11.5	0.6	0.6	0.5	0.6	5.4	4.9	4.9	5.1	3.3	9.3	508	507	508	508	670
2200	481	481	484	13.2	13.1	13	0.7	0.6	0.5	0.6	4.8	4.4	4.6	4.6	3.6	10.92	502	499	500	500	660
2300	481	480	483	14.8	14.7	14.6	0.7	0.6	0.6	0.6	4.2	3.9	4.2	4.1	3.6	12.3	494	493	494	494	646
2400	482	481	484	17.1	16.9	16.7	0.7	0.5	0.6	0.6	3.5	3.1	3.6	3.4	3.4	14.1	484	482	482	483	632

**Table 1: Factory Test Results on 4 × 3.75 HP EC Fans with a Harmonic Filter Designed for Low DC Bus Capacitance**

On another application, testing for IEEE Std 519 compliance was completed on a custom air handler (STULZ model CAH-0310-050K-F0H) at the STULZ factory in Frederick, MD. This unit is equipped with six EC fans at 5 HP each. Testing was performed at four operating levels including the design maximum fan speed at which the fan loading was about 70% of its full load rating. At this load level, total harmonic current distortion, THDi, was slightly above 5% but harmonic content was significantly < 5% when calculated for total demand distortion, TDDi (TDDi = THDi × % Total Demand Current). The complete test results are shown in Fig. 13. TDDi was < 5% at all load levels. Also, THDv did not increase over the background distortion level under any operating condition and remained well below 5%.

## Summary and Conclusion

To reduce energy consumption in today's modern facilities, Air Handling Systems incorporating electronically commutated fans are becoming more commonly used. When large quantities of these fans are employed however, the substantial energy savings and operational benefits might come at the cost of high harmonic distortion levels. This is also true when AC VFD systems are used to control fan speed.

The challenge of reducing harmonics generated by EC fans can be different than with AC VFD systems due to their very low DC bus capacitance. This low capacitance shifts the resonant point of the circuit between the filter and the rectifier/inverter to a value above the prevalent harmonics being generated by the rectifier. The impedance of standard harmonic filters will tend to shift this resonant point down and into a region where the harmonics will be amplified creating instability, overheating, high DC bus voltage levels and even component failure.

A harmonic filter designed for modern EC fans can provide excellent harmonic mitigation without introducing unstable operation of the fans. When applied to the AHUs for a mission critical Data Center, power quality measurements confirmed that this solution allowed for the use of EC fans while meeting the requirements of IEEE Std 519.

## References

ebm-papst, “GreenTech EC Technology”, 37854-7-8811, 2016-04

ebm-papst, “Reducing Energy Consumption in the Built Environment through EC Fan Technology”, [http://www.greensenseplus.com/sites/default/files/ebm-papst\\_CPD.pdf](http://www.greensenseplus.com/sites/default/files/ebm-papst_CPD.pdf)

Gunter Streng, Efficient, Compact EC Motors for High Performance Fans and Blowers: The Future of Refrigeration, Air Conditioning and Building Systems, Appliance Design, Oct. 2015

IEEE Std 519-2014, IEEE Recommended Practices and Requirements for Harmonic Control in Electrical Power Systems, New York, NY: IEEE

A.H. Hoevenaars, P. Hoevenaars, “Data Center Cooling Harmonics – How to Get the Good without the Bad”, IEEE I&CPS Virtual Conference, Apr. 2020

MIRUS Intl, “The Modern Hospital/Health Care Environment & Harmonics”, MIRUS-TP004-A1, Mar. 2020

## AUTHORS

**Anthony Hoevenaars**

Mirus International Inc.

**Dave Meadows**

STULZ Air Technology Systems, Inc.

**Joe Landrette**

ebm-papst Inc.



Model: CAH-0310-050K-F0H(L/R)  
S/N: 10314226

Case: 100% Fan Speed				
Motor FLA	A	7.4		
Total FLA (= Motor FLA x 6)	A	44.4		
	-	<b>A1</b>	<b>A2</b>	<b>A3</b>
Current	A	30.4	29.8	30.0
% of Total Demand Current	%	68.5%	67.1%	67.6%
THDi	%	6.5%	4.7%	6.0%
TDDi	%	4.5%	3.2%	4.1%
<b>Average TDDi</b>	%	<b>3.9%</b>		
	-	<b>U1</b>	<b>U2</b>	<b>U3</b>
Voltage	V	477.5	475.3	478.4
THDv	%	1.3%	1.1%	1.3%
<b>Average THDv</b>	%	<b>1.2%</b>		

**Comments**  
at 60 Hz  
Maximum Load Current  
  
Total Harmonic Distortion of Current  
Total Demand Distortion of Current  
TDDi = THDi x % of Total Demand Current  
< 5%  
  
Total Harmonic Distortion of Voltage  
< 5%

Case: 75% Fan Speed				
Motor FLA	A	7.4		
Total FLA (= Motor FLA x 6)	A	44.4		
	-	<b>A1</b>	<b>A2</b>	<b>A3</b>
Current	A	16.6	16.3	16.6
% of Total Demand Current	%	37.4%	36.7%	37.4%
THDi	%	10.0%	7.7%	9.2%
TDDi	%	3.7%	2.8%	3.4%
<b>Average TDDi</b>	%	<b>3.3%</b>		
	-	<b>U1</b>	<b>U2</b>	<b>U3</b>
Voltage	V	480.2	477.8	481.5
THDv	%	1.6%	1.5%	1.4%
<b>Average THDv</b>	%	<b>1.5%</b>		

at 60 Hz  
Maximum Load Current  
  
Total Harmonic Distortion of Current  
Total Demand Distortion of Current  
TDDi = THDi x % of Total Demand Current  
< 5%  
  
Total Harmonic Distortion of Voltage  
< 5%

Case: 50% Fan Speed				
Motor FLA	A	7.4		
Total FLA (= Motor FLA x 6)	A	44.4		
	-	<b>A1</b>	<b>A2</b>	<b>A3</b>
Current	A	9.1	9.0	9.2
% of Total Demand Current	%	20.5%	20.3%	20.7%
THDi	%	13.8%	10.9%	12.9%
TDDi	%	2.8%	2.2%	2.7%
<b>Average TDDi</b>	%	<b>2.6%</b>		
	-	<b>U1</b>	<b>U2</b>	<b>U3</b>
Voltage	V	482.0	479.6	483.3
THDv	%	1.2%	1.0%	1.3%
<b>Average THDv</b>	%	<b>1.2%</b>		

at 60 Hz  
Maximum Load Current  
  
Total Harmonic Distortion of Current  
Total Demand Distortion of Current  
TDDi = THDi x % of Total Demand Current  
< 5%  
  
Total Harmonic Distortion of Voltage  
< 5%

Case: 25% Fan Speed				
Motor FLA	A	7.4		
Total FLA (= Motor FLA x 6)	A	44.4		
	-	<b>A1</b>	<b>A2</b>	<b>A3</b>
Current	A	8.7	8.6	8.8
% of Total Demand Current	%	19.6%	19.4%	19.7%
THDi	%	7.0%	5.0%	6.4%
TDDi	%	1.4%	1.0%	1.3%
<b>Average TDDi</b>	%	<b>1.2%</b>		
	-	<b>U1</b>	<b>U2</b>	<b>U3</b>
Voltage	V	482.0	479.3	482.2
THDv	%	1.2%	1.1%	1.1%
<b>Average THDv</b>	%	<b>1.1%</b>		

at 60 Hz  
Maximum Load Current  
  
Total Harmonic Distortion of Current  
Total Demand Distortion of Current  
TDDi = THDi x % of Total Demand Current  
< 5%  
  
Total Harmonic Distortion of Voltage  
< 5%

**Fig. 11: Factory Test Report for Harmonic Compliance on a Data Center Custom Air Handler**



## **ABOUT MIRUS INTERNATIONAL INC.**

Since 1991, Mirus International has been a supplier of specialized power quality products to reduce or eliminate harmonic problems and save energy in electrical power distribution systems worldwide. As true innovators, our unique approach to harmonic mitigation has produced many patented designs useful in addressing the problems associated with harmonic generating non-linear loads such as Adjustable Speed Drives (ASDs), both AC and DC, personal computers and other power electronic devices. Markets include Oil & Gas (drilling and pumping applications), Water/Waste Water, Chillers and other HVAC equipment, Marine vessels, Data Centers (servers and cooling equipment), Telecommunications and Broadcasting facilities.



## **ABOUT STULZ USA**

STULZ Air Technology Systems, Inc. (STULZ USA) is an ISO 9001 registered manufacturer of environmental control equipment and is responsible for product development, manufacturing, and distribution for the North American arm of the international STULZ Group. STULZ provides user driven, custom designed and purpose built precision cooling, ultrasonic humidification and desiccant dehumidification solutions for mission critical applications. We go above and beyond to provide our customers with the ideal solution for their application, often designed and manufacturing a fully custom cooling solution, designed by our team of engineers located at our manufacturing facility and US headquarters in Frederick, Maryland.



## **ABOUT EBM-PAPST INC.**

With offices in major cities throughout North America, our highly-skilled and experienced team of professionals is ready to tackle your most difficult air moving challenges and offer solutions that meet your needs. We at ebm-papst are "Engineering a Better Life" through our commitment to innovation in green technology. We serve all markets including Data Centers, Air-conditioning and Ventilation, Automotive, Commercial Refrigeration, Heating, Industrial, IT / Telecom, Medical, Transportation and more. You can always count on prompt, courteous service. Customer satisfaction is our number one priority.



**STULZ AIR TECHNOLOGY SYSTEMS, INC.**

1572 Tilco Drive | Frederick, MD 21704

Tel. 301.620.2033 | Fax 301.662.5487

[www.stulz-usa.com](http://www.stulz-usa.com)



**MIRUS INTERNATIONAL**

31 Sun Pac Blvd. | Brampton, Ontario L6S 5P6

Tel. 905.494.1120 | Fax 905.494.1140

[www.mirusinternational.com](http://www.mirusinternational.com)



**ebm-papst**

100 Hyde Road | Farmington, CT 06034

Tel. 860.674.1515 | Fax 860.674.8536

[www.ebmpapst.us](http://www.ebmpapst.us)