

Rev. No.	Revision Note	Date	By	Checked
A6	REVISED REACTOR DESIGN	05-OCT-2021	CG	BDK
A7	ADDED UPPER BRACING	27-MAR-2024	AD	BDK

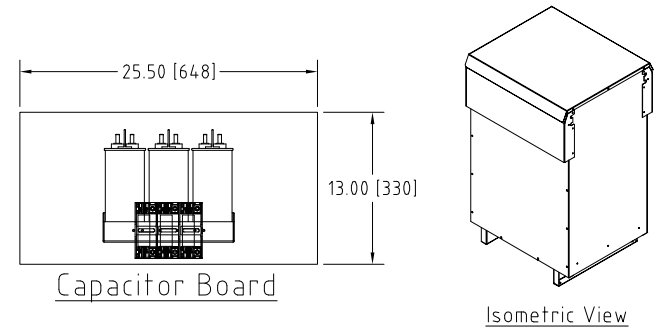
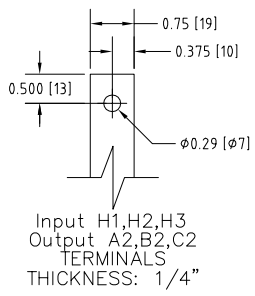
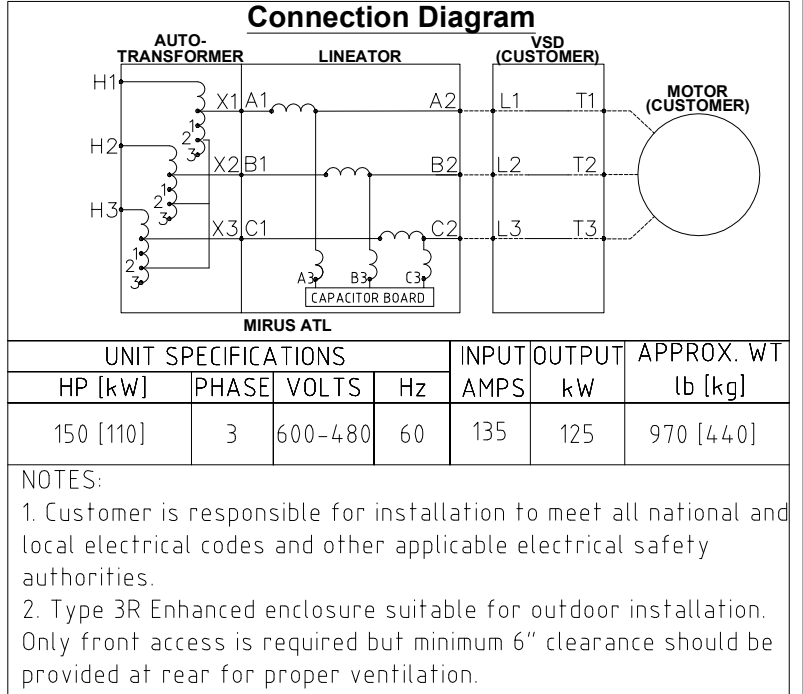
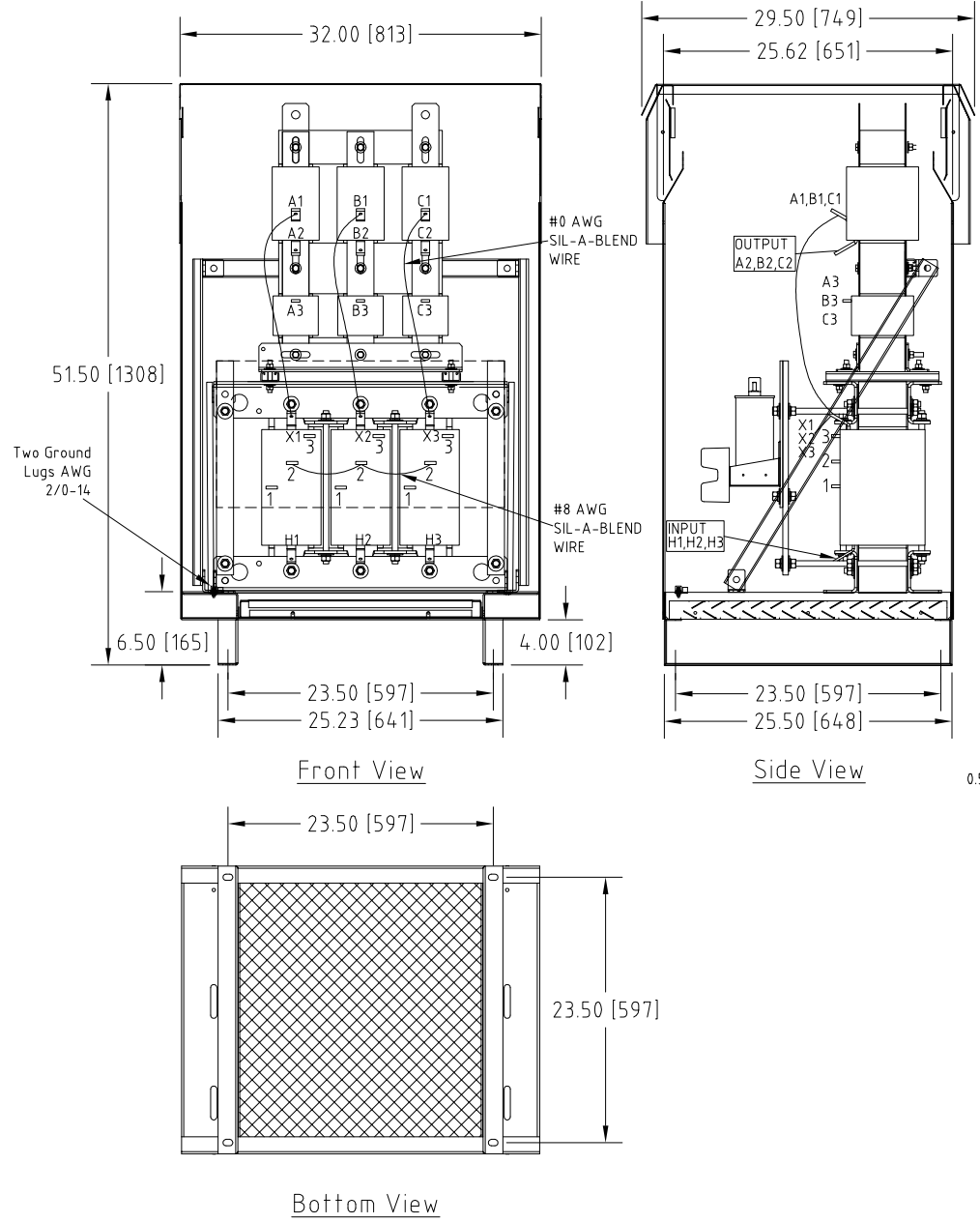

**MIRUS International Inc.** 31 Sun Pac Boulevard, Brampton, ON, Canada L6S 5P6  
 Tel:(905) 494-1120 Fax: (905) 494-1140 Toll Free: 1-888-TO MIRUS

Unless otherwise specified, dimensions are in inches and [mm].	Drawn By YM	Date Created 08-JUN-12	Checked by CG	Approved by - date CG-09-JAN-2019	Scale NTS
--	----------------	---------------------------	------------------	--------------------------------------	--------------

The information contained herein is the sole property of MIRUS International Inc. Any form of reproduction, distribution and/or disclosure of this information, all or in part, is strictly prohibited without the express written consent of MIRUS International Inc.

Title 150HP, 600-480V, 60Hz Enh. Enclosed Style Translineator ATL	Revision A7	Sheet 1/1
---	----------------	--------------

Filename: ATL-150-(600-480)-60-D-E1E-A7