

REV	DESCRIPTION	DATE	BY	APP
1	REVISED TERMINAL BLOCK	14-JUN-2022	CG	AH

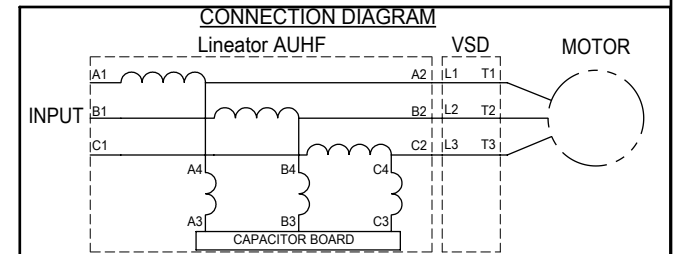

UNIT SPECIFICATIONS				INPUT AMPS	OUTPUT AMPS	OUTPUT kW	HEAT LOSS W	APPROX. WT lbs [kg]
HP [kW]	PHASE	VOLTS	Hz					
7.5 [5.5]	3	600	60	7	7	6.3	83	45 [20]
10 [7.5]				10	11	8.5	112	55 [25]
15 [11]				14	15	13	171	60 [27]
20 [15]				18	19	17	224	70 [32]

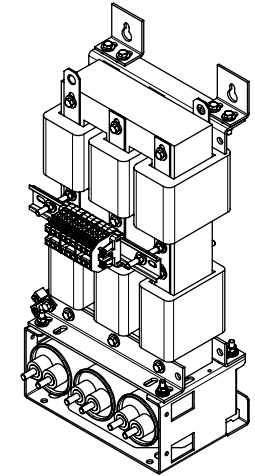
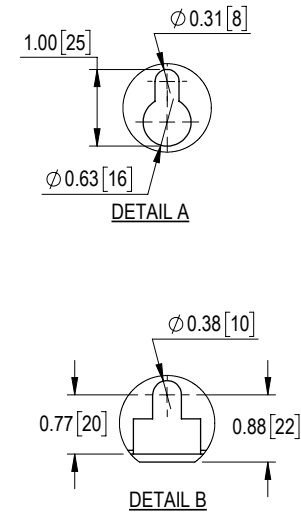
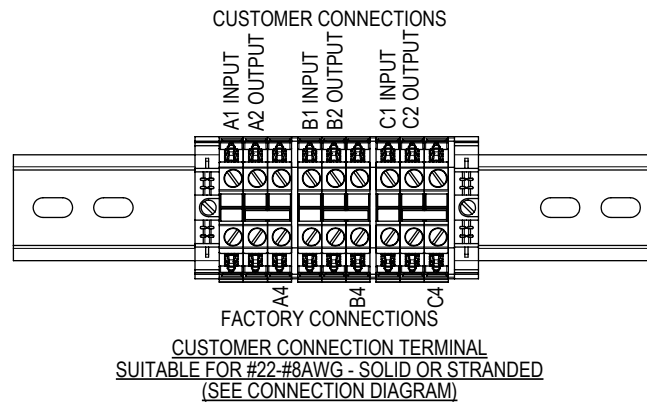
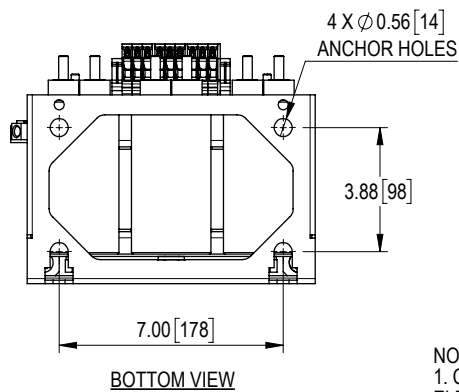
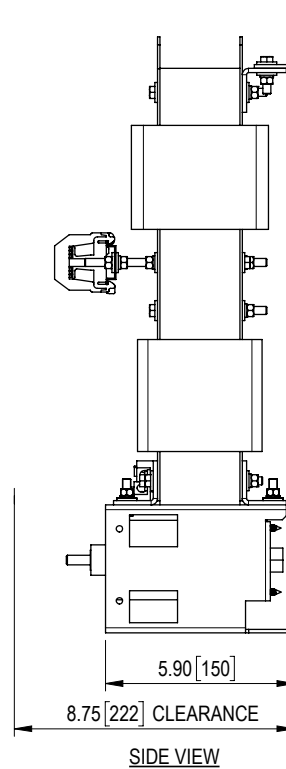
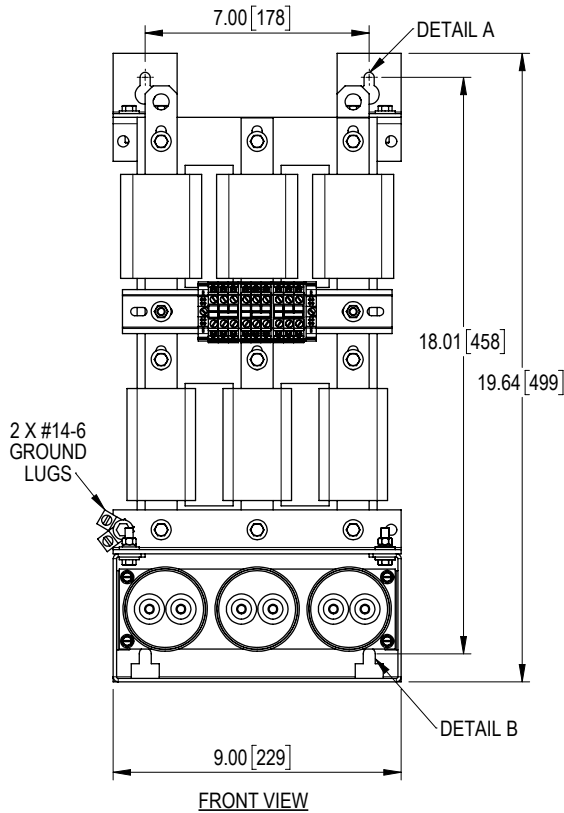

THE INFORMATION CONTAINED HEREIN IS THE SOLE PROPERTY OF MIRUS INTERNATIONAL INC. ANY FORM OF REPRODUCTION, DISTRIBUTION AND/OR DISCLOSURE OF THIS INFORMATION, ALL OR IN PART, IS STRICTLY PROHIBITED WITHOUT THE EXPRESS WRITTEN CONSENT OF MIRUS INTERNATIONAL INC.

DRAWN CG
SCALE NTS

APPROVED BDK
DATE 21-DEC-2021

MIRUSInternational Inc.
31 Sun Pac Boulevard, Brampton Ontario Canada L6S 5P6
1-888-TO MIRUS www.mirusinternational.com

TITLE

7 to 20 HP, 600 V, 60Hz
LINEATOR AUHF, PANEL MOUNT

ELEC FILE NO.	DRAWING NO.	SHT OF	REV
AUHF-7to20-600-60-D-EX-R1	AUHF-7to20-600-60-D-E0P	1 OF 1	1

- NOTES:
1. CUSTOMER IS RESPONSIBLE FOR INSTALLATION TO MEET ALL NATIONAL AND LOCAL ELECTRICAL CODES AND OTHER APPLICABLE ELECTRICAL SAFETY AUTHORITIES.
 2. CUSTOMER IS RESPONSIBLE FOR PROPER COOLING OF FILTER COMPONENTS. ALLOWED AMBIENT: MAXIMUM 60 °C, MINIMUM -40 °C. A MINIMUM CLEARANCE OF 2" MUST BE ALLOWED ON BOTH RIGHT AND LEFT SIDES. PROPER VENTILATION MUST ENSURE THAT SUPPLY AIR FLOWS THROUGH THE REACTOR COILS FROM BELOW THE UNIT.